

Standard Water

“GX” Series

Gas Fired Humidifier

Looking for an alternative to electrically generated steam humidification? Concerned about using chemically treated boiler steam for direct humidification? If so, PURE's "GX" Series (patent no. 6,705,535) Gas Fired Humidifiers are exactly what you're looking for.

Indoor air quality issues concerning the use of boiler steam for direct humidification have resulted in a growing apprehension for the use of "steam injection" type humidifiers. The possible carry-over of chemical additives and odor created within some boiler systems are being addressed in an effort to improve the indoor air quality for new and existing buildings. The alternative, electric humidifiers, can be prohibitive due to the higher energy costs associated with electrically generated steam, versus the typically lower energy cost of natural gas. For these reasons, PURE has developed the "GX" Series Gas Fired Humidifier.

The "GX" Series Humidifiers utilize a stainless steel heat exchanger, which allows for a gas power burner to be used as the energy source for producing steam from tap water.

The steam produced by the "GX" Series Humidifier is free from chemical or mineral carry-over, providing pure humidification for today's stringent indoor air quality requirements. PURE's highly efficient heat exchanger produces combustion efficiencies up to 84%, as well as providing simplified maintenance. The unique side entry heat exchanger can be removed without removing the cover and injection tube system, and provides a large clean-out opening which extends the full length of the humidifier. Furthermore, the unique design allows for easy removal of the gas burners.

PURE's commitment to quality and ease of maintenance is further illustrated by the use of pressure clamps that secure the heat exchanger to the reservoir and eliminate the need for through-the-wall threaded fasteners. The humidifiers utilize a Tri-Probe sensor and a flusher, which removes water mineral build-up during each fill cycle, and doubles as a water overflow safety pipe to drain. An accumulative timed drain cycle performs automatic draining and flushing, further reducing mineral build-up within the reservoir. Precise modulation of the humidifier output is maintained by a high quality gas burner which modulates the gas flow into the heat exchanger.

Each humidifier is supplied with an INTAC[®] control system mounted in a NEMA-12 enclosure. The INTAC[®] microprocessor control system provides constant monitoring of the water level and safety systems, as well as providing a gas valve interlock. This will prevent operation, should any of the safety circuits open.

The "GX" humidifiers come standard with free-standing support legs, factory mounted control panel, factory insulation and DCT-927 drain tempering kit. A flexible hose kit is available for remote mounting of the humidifier from the injection tube. Multiple injection tubes are available for improved dissipation of the steam in large ducts or manufactured air handling systems. Multiple humidifiers can be manifolded together to a single injection tube system to provide increased capacity on large air volume projects.

The versatility of the "GX" Series will allow you to design them into any system simply, efficiently and reliably.

Our results are comforting



Capacities, Electrical & Weights

Sheet No.
GX-2

This humidifier is a forced combustion type that can be used with natural gas or liquid propane. The burner can be easily removed to access the side entry exchanger for cleaning. It is designed to work with low-pressure gas between 5" W.C. up to 14" W.C.

Unit Capacities in Pounds per Hour (kg/hr)† Weights in lbs. (kg) and Electrical Specification

Standard Water Unit Model No.	Steam Capacity Lb/Hr (kg/Hr)	No. of Burners	*BTU Input	Exhaust Manifold Vent Size (cm)	Shipping Weight (kg)	Operating Weight (kg)	120 Volt, 60 Hz
							Full Load Amps
GX-3	110 (49.9)	1	150,000	4" (10.2)	201 lbs. (91.2)	420 lbs. (190.5)	5.0
GX-4	300 (136.1)	1	400,000	4" (10.2)	390 lbs. (176.9)	710 lbs. (322.1)	5.0
GX-8	600 (272.2)	2	800,000	6" (15.2)	827 lbs. (375.1)	1391 lbs. (630.9)	10.0
GX-12	900 (408.2)	3	1,200,000	8" (20.3)	1125 lbs.(510.3)	2072 lbs. (939.9)	15.0

† Actual humidifier capacity may vary due to the heat loss from the humidifier reservoir. The ambient air temperature, air velocity and injection tube system will affect the rate of heat loss from the reservoir.

* Altitude adjustment:

100% up to 2000'

Over 2000', 4% de-rate per 1000'

Gas Piping Pressure Drop Data

EQUIVALENT LENGTH OF STRAIGHT PIPE IN FEET									
	20	30	40	20	60	80	100	150	200
CFH GAS WITH .2" PRESSURE DROP									
Pipe Size in Inches									
3/4"	152	120	105	93	84	73	66	54	45
1"	300	250	210	190	180	150	135	110	75
1 1/4"	520	425	360	325	300	260	230	190	165
1 1/2"	800	690	560	500	480	410	370	300	260
2"	1700	1400	1200	1100	1000	850	750	600	540
2 1/2"	3000	2500	2100	1900	1800	1550	1375	1100	950
EQUIVALENT LENGTHS OF STANDARD PIPE IN FEET FOR LISTED FITTINGS									
Fitting Type	3/4	1	1 1/4	1 1/2	2	2 1/2	Nominal		
Std. Tee	2.4	5.5	7.5	9	12	13.5	Pipe Size		
Std. Elbow	4.4	2.7	3.7	4.5	5.5	6.1	in Inches		

Gas Input CFH for GX-Series Humidifiers

Model	Max BTU/Hr Input	Max CFH (Nat. Gas)	Max CFH (Propane)
GX-3	150,000	150	60
GX-4	400,000	400	160
GX-8	800,000	800	320
GX-12	1,200,000	1200	480

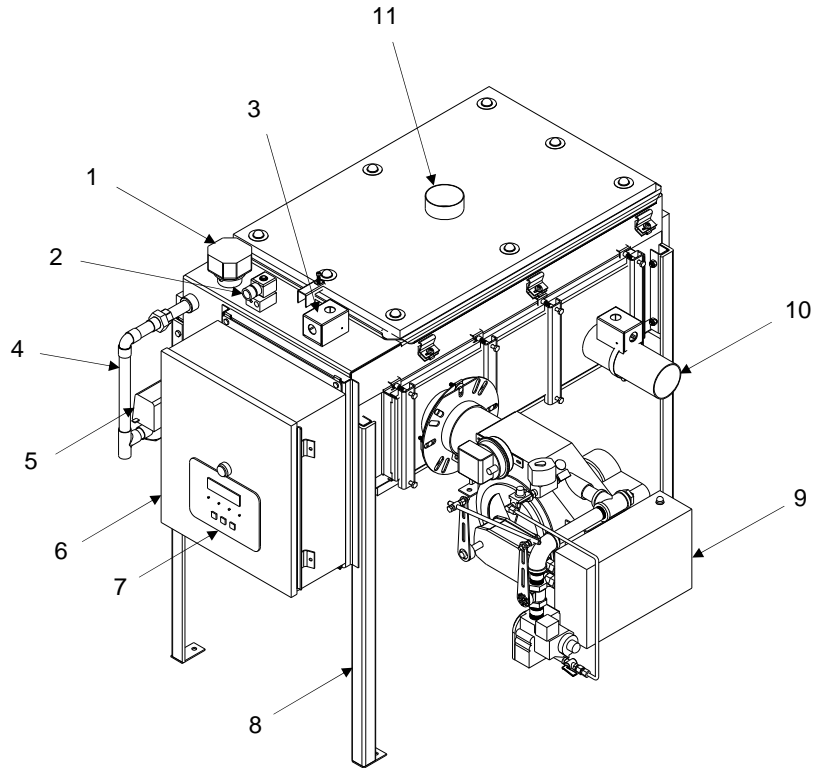

Features

- | | |
|------------------------------------|--------------------------------------|
| 1. Tri-Probe Sensor | 7. INTAC [®] Microprocessor |
| 2. 1/4"-NPT Water Inlet & Strainer | 8. Support Legs |
| 3. Over Temperature Cut-Out Switch | 9. Burner Assembly |
| 4. Flusher & Overflow Piping | 10. Exhaust Connection |
| 5. 3/4" Motorized Drain Valve | 11. Steam Outlet Connection |
| 6. Control Panel | |

Required Clearance:

For recommended service and maintenance purposes the following clearances should be maintained:

- Right side, see Top View for required clearance
- Front side, NEC requires 36" clearance to control cabinet
- Left side, 6" for access
- Rear, 6" for access
- Top, 12" for cover and Tri-Probe removal

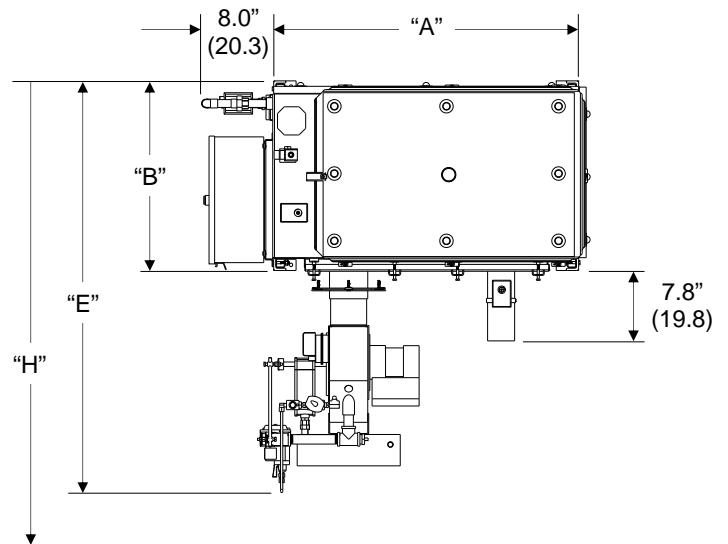

Top View

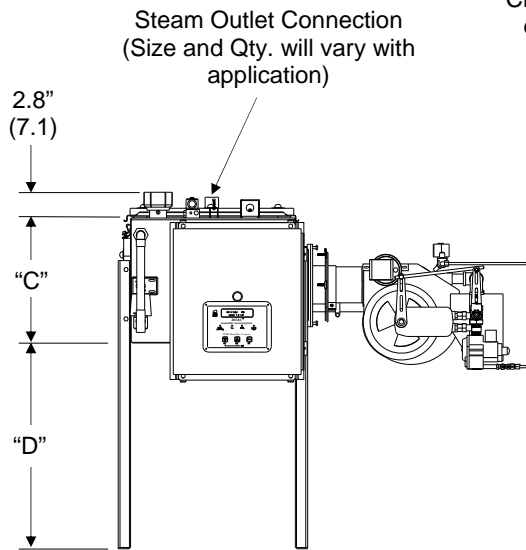

Front View

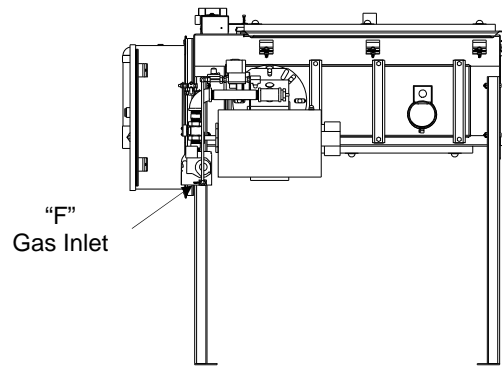

Right Side View

Unit Dimensions in Inches (cm)

Standard Water Unit Model No.	Dim. "A"	Dim. "B"	Dim. "C"	Dim. "D"	Dim. "E"	Dim. "F"	Dim. "G"	Dim. "H"
GX-3	34.0" (86.4)	21.1" (53.7)	13.8" (34.9)	24.0" (60.9)	45.9" (116.5)	3/4"-NPT	3.0" (7.62)	50.0" (127.0)
GX-4	54.0" (137.2)	30.1" (76.5)	13.8" (34.9)	24.0" (60.9)	54.7" (138.9)	3/4"-NPT	3.0" (7.62)	66" (167.6)

Heat exchangers have a top and bottom. There is a break (crease) on the bottom side of the heat exchanger. Do not install heat exchanger upside-down.
All dimensions are approximate and subject to change at manufacturer's discretion.

Required Clearance:

For recommended service and maintenance purposes the following clearances should be maintained:

Right side, see Top View for required clearance

Front side, NEC requires 36" clearance to control cabinet

Left side, 6" for access

Rear, 6" for access

Top, 12" for cover and Tri-Probe removal

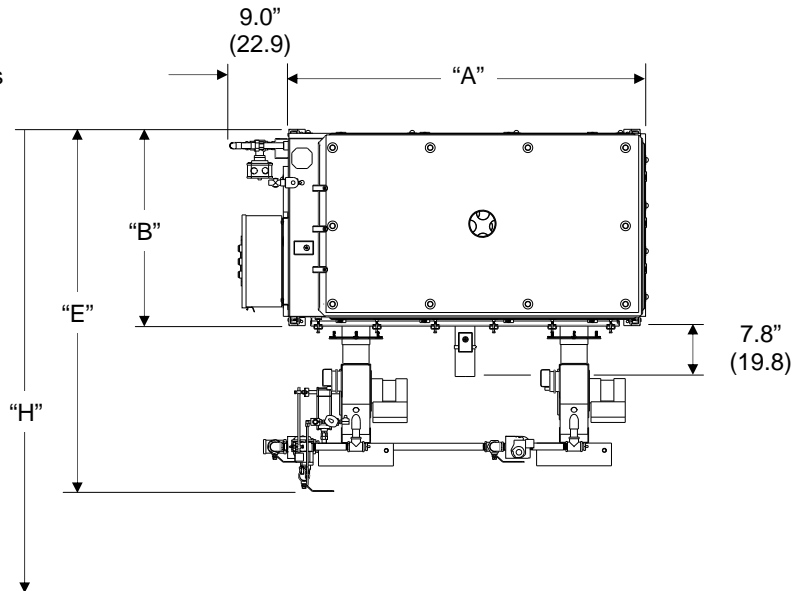

Top View

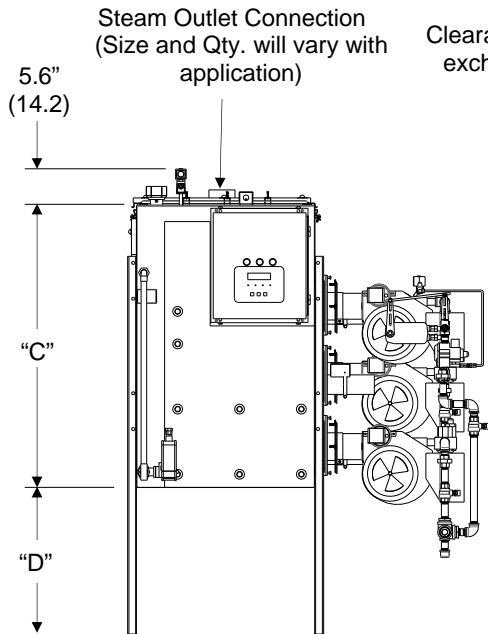

Front View

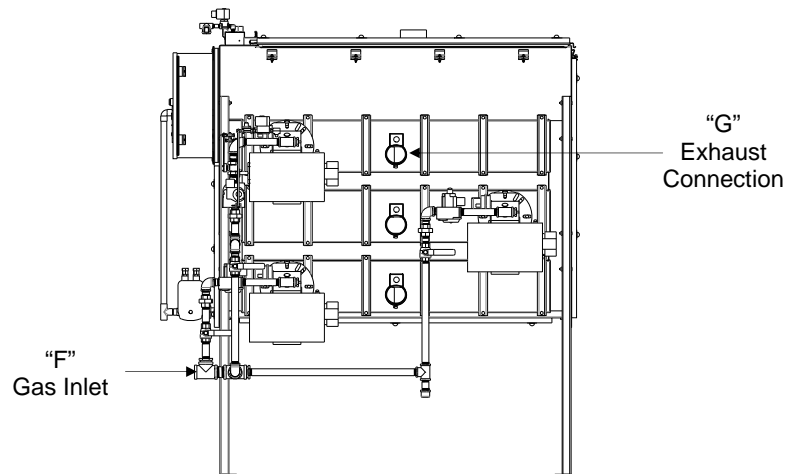

Right Side View

Unit Dimensions in Inches (cm)

Standard Water Unit Model No.	Dim. "A"	Dim. "B"	Dim. "C"	Dim. "D"	Dim. "E"	Dim. "F"	Dim. "G"	Dim. "H"
GX-12	54.0" (137.2)	31.1" (76.5)	43.5" (110.5)	24.0" (60.9)	55.8" (141.1)	1-1/4"-NPT	3.0" (7.6)	66.0" (167.6)

Heat exchangers have a top and bottom. There is a break (crease) on the bottom side of the heat exchanger. Do not install heat exchanger upside-down.

All dimensions are approximate and subject to change at manufacturer's discretion.

Required Clearance:

For recommended service and maintenance purposes the following clearances should be maintained:

- Right side, see Top View for required clearance
- Front side, NEC requires 36" clearance to control cabinet
- Left side, 6" for access
- Rear, 6" for access
- Top, 12" for cover and Tri-Probe removal

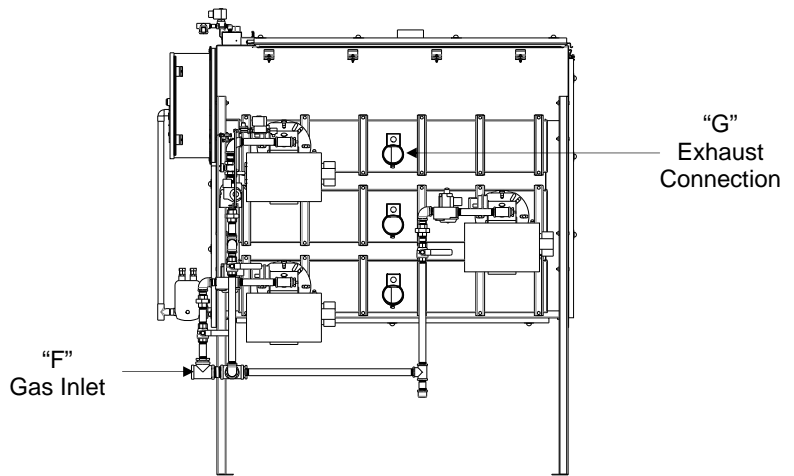
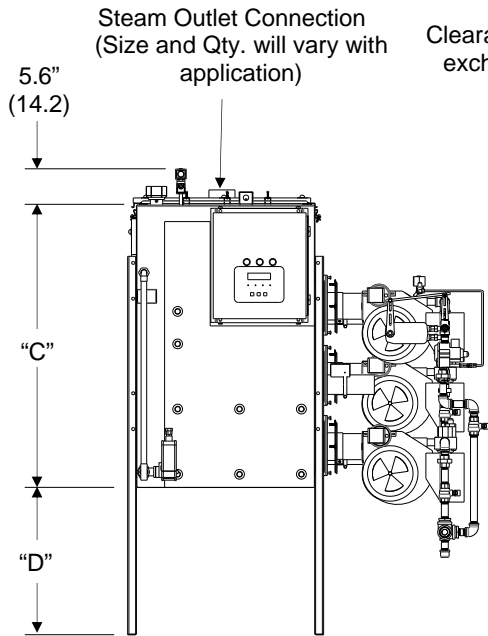
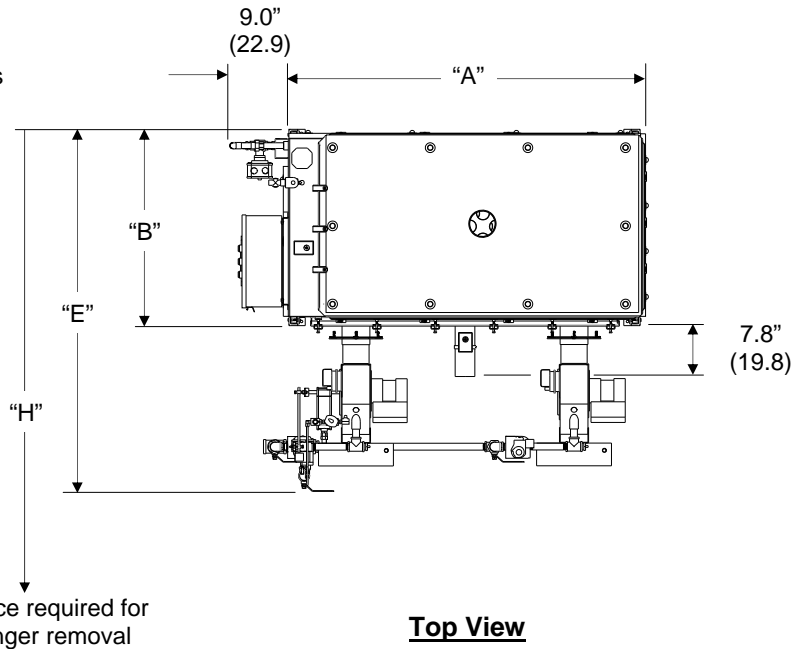

Unit Dimensions in Inches (cm)

Standard Water Unit Model No.	Dim. "A"	Dim. "B"	Dim. "C"	Dim. "D"	Dim. "E"	Dim. "F"	Dim. "G"	Dim. "H"
GX-12	54.0" (137.2)	31.1" (76.5)	43.5" (110.5)	24.0" (60.9)	55.8" (141.1)	1-1/4"-NPT	3.0" (7.6)	66.0" (167.6)

Heat exchangers have a top and bottom. There is a break (crease) on the bottom side of the heat exchanger. Do not install heat exchanger upside-down.
All dimensions are approximate and subject to change at manufacturer's discretion.



Specification Sample
"GX" Series

Sheet No.
GX-7

Humidifier

1. The humidifier (patent no. 6,705,535) shall be forced draft combustion gas burner type humidifier as manufactured by PURE Humidifier Co. of Chaska, Minnesota.
2. The humidifier shall be tested and approved by ETL/ETL-C Testing Laboratories, Inc to AGA/CGA standards.
3. The humidifier shall have an evaporating reservoir with a gasket sealed cover which is capable of operating at pressures of at least 19"-48 cm (W.C.) without steam or water leaks. The reservoir shall be made of type 304 stainless steel with welded joints.
4. The humidifier shall be designed to facilitate easy removal of the gas heat exchanger for periodic scale removal and inspection. The cover and gas heat exchanger shall be secured to the unit by the use of quick release clamps. The gas heat exchanger shall be removable from the side of the humidifier without disturbing the cover or injection tube system's steam supply piping.
5. The gas heat exchanger shall be constructed of type 304 stainless steel with 2" round heat transfer tubes. Tubes shall be self cleaning via expansion and contraction of tubes. Coating of tubes is not required.
6. The humidifier shall require only 2 sides for service access.
7. The forced draft combustion burner shall be capable of expelling flue gases up to 100 ft (31 m) without the use of a power vent (sidewall or roof vented).
8. Unit shall be covered (except front face) with 3/4" (1.90 cm) thick fiberglass duct insulation. Insulation material shall have aluminum facing.
9. Provide support legs made of 1 1/4" x 1 1/4" x 1/4" (3.2 cm) angle iron and painted with enamel gray paint. Distance from humidifier bottom to floor shall be 24" (61 cm).
10. Humidifier control cabinet shall be factory mounted and wired to the face of the humidifier reservoir.
11. An adjustable surface water flusher shall be included to drain away a portion of the water upon each refill cycle. This will allow mineral deposits produced by earlier evaporation cycles to be removed.
12. A brass body, solenoid operated water fill valve shall be factory mounted on the top near the front of the humidifier reservoir. The fill valve shall be located to allow a minimum water gap of 1 1/2" (3.81 cm). An inline strainer shall be factory mounted upstream of the fill valve to remove any water born particulate matter before the humidifier fill valve. The water strainer shall have a removable screen to permit periodic inspection and cleaning.
13. The humidifier is supplied with a DCT-927 temperature actuated drain tempering kit. The drain tempering kit is designed to provide drain water temperature of less than 140°F (shipped loose).
14. The humidifier shall be provided with an ETL listed JIC NEMA 12 control cabinet, shipped factory mounted and wired to the reservoir. The control cabinet shall be made of 14 gauge steel with ANSI 61 gray polyester powder coating, continuous hinge and oil-resistant gasket. The panel shall include a factory wired sub-panel with gas valve interlock, fused control circuit transformer, numbered terminal block and main power fuse(s).
15. The control system shall maintain humidification during the fill cycle to maintain a consistent relative humidity.
16. An INTAC® programmable electronic microprocessor humidifier control system shall be mounted and pre-wired to the humidifier control panel door. The INTAC® controller shall provide digital display of all humidifier functions.

Reference the "Options" page for a description of the options which can be added to the base specification.



INTAC[®] Specification Sample "GX" Series

Sheet No.
GX-8

An INTAC[®] programmable electronic microprocessor humidifier control system shall be mounted and pre-wired to the humidifier control panel door. All humidifier electrical, ground and control terminal connections shall be enclosed in an ETL listed NEMA 12 enclosure. The INTAC[®] controller shall provide the following standard features:

- Self-diagnostics and system verification on start-up.
- Evaporating reservoir water level verification, control and safety interlock. The controller shall be compatible with all water types.
- Automatic reservoir drain and flush system. The controller shall periodically drain and flush the reservoir based on Accumulated Run Time, Elapsed Time or by an externally triggered dry contact closure (except RO/DI water).
- Cold water tempering prevents excessively hot water from draining during an automatic or seasonal drain cycle.
- Seasonal Drain system shall automatically drain the humidifier reservoir after a selected "NON-USE" period. The controller shall automatically reset the humidifier on a call for humidity (if utilized).
- Safety circuit input terminals including over-temperature shut down.
- Terminal connections to accept virtually all control input signals. Input control range is selected as an "ON-SCREEN" prompt.
- User adjustable controlling and high-limit RH PID functions with adjustable parameters (if utilized).
- Door-mounted display and user interface. Provides two lines of system messaging on a vacuum fluorescent display screen, LED operational indication and keypad parameter entry system.
- Vacuum fluorescent display brightness is adjustable.
- Adjustable input signal filter to attenuate noisy control input signal.
- Numbered screen prompts for set-up and service identification.
- Keypad lock-out with user selected access levels.
- Time-delayed scrolling display loop will begin cycling ten minutes after no buttons have been pressed and will display the next item for 30 seconds before continuing down the list – displays system parameters including: Low and High RH Alarms, System Faults, System Status, Set Point and Actual Space RH, Set Point and Actual Duct RH (optional), Outdoor Air Temperature (optional), Percent Power Output, Humidifier Output (in lbs/hr or kg/hr), Accumulated Run Time, Time to Clean timer, Water Level, Water Temperature Set Point and Actual (optional) and Control Type.

- INTAC[®] controller will automatically shut down when the ambient temperature is outside of designed operating temperature range.
- Full Networking and BAS communication capability. Communication connections shall provide two-way communication via EIA-485 connected Modbus between the INTAC[®] controller and the Building Automation System (BAS) (if utilized).
- High/Low humidity deviation alarm contacts (modulating control only).
- Multiple humidifiers can run off of one control signal from a BAS system. Humidifiers can be set up to run in parallel or in series.
- Safety Circuit/System Fault/Low Water alarm contacts.
- Flash Memory – allows system upgrades through EIA-485 terminal connections with a laptop computer and access to e-mail.

OPTIONAL FEATURES

- A. Variable air volume (VAV) anticipation control. The INTAC[®] software shall accept a modulating high-limit humidity input and space controlling RH input, then modulates the heater output to prevent over saturation of the supply air due to changes in the quantity of air flow. A compatible humidity sensor shall be shipped loose for field installation.
- B. Cold weather relative humidity reset. The INTAC[®] software shall accept a modulating temperature input and automatically reduce the space RH set-point on a drop in the outside temperature. The reduction of the RH set-point during cold weather periods prevents damage due to interior window condensation.
- C. Reservoir thermocouple water temperature control. The INTAC[®] software provides standby water temperature sensing and freeze protection.
- D. A remote wall mount INTAC[®] user interface keypad/display module shall be furnished

Reference the "Specification Sample" for the humidifier base specification.



Options "GX" Series

Sheet No.
GX-9

To Humidifier

Cold Water Tempering. A factory installed temperature sensor shall be mounted onto the humidifier reservoir. Prevents excessively hot water from draining during an automatic or seasonal drain cycle.

Freeze Protection. A factory installed temperature sensor shall be mounted onto the humidifier reservoir. The system shall maintain the water temperature above freezing.

Standby Water Temperature Sensing. Consists of a temperature sensor to maintain water temperature at a selected level for fast response upon a call for humidity.

Injection Tubes

Injection tube(s) and Flexible Hose. Each unit shall include one or more 10 ft. (305 cm) sections of 1 ½" (3.8 cm) I.D. flexible hose and a 1 ½" (3.8 cm) O.D. stainless steel injection tube long enough to extend across the duct. Steam ports shall direct steam upward into the airflow. The reservoir cover shall have a matching connection so the flexible hose can be connected with two stainless steel hose clamps. A two-piece duct plate shall be provided to seal the duct opening.

Fast-Pac Multiple Tube Assembly. Tube assembly consists of a stainless steel supply/condensate header with a 3/4"-NPT drain connection and horizontal 1 1/2"Ø stainless steel injection tubes.

Insty-Pac Multiple Tube Assembly. Tube assembly consists of a steam supply/separator header constructed of stainless steel with steam inlet, condensate drain outlet and steam jacketed injection tubes welded to header. Steam jacketed injection tubes constructed of stainless steel with punched steam ports of the proper size and spacing to deliver the maximum specified capacity.

To Control Cabinet

Control Panel Door Lock. Control cabinet shall be provided with a factory installed key lock on the cabinet door.

Controls

VAV Control. The INTAC® software shall accept a modulating high-limit humidity input and space controlling RH input and modulate the heater output to prevent over saturation of the supply air due to changes in the quantity of airflow. A compatible space and duct humidity sensor shall be shipped loose for field installation.

Air Flow Proving Switch. A diaphragm operated air flow proving switch with adjustable range of .05" W.C. to 2.0" W.C. shall be provided for field installation.

Duct High-Limit. A high-limit humidistat shall be provided for duct installation. The high-limit shall be field set to prevent over saturation within the supply duct.

Venting

Sealed Combustion Air Kit. Consists of a 5" round stainless steel adaptor that allows outside air to be piped directly to the intake of the burner for combustion.

Outdoor Enclosure. Curb/slab mounted weather proof enclosure. Humidifier is factory installed and shipped in enclosure, ready for field gas, water and electrical connections. Unit is ETL listed.

Reference the "Specification Sample" for the humidifier base specification.